



# 5/8" BORE ACCESSORIES



## CB-0895

Clevis Bracket  
Material: steel, bright zinc plated

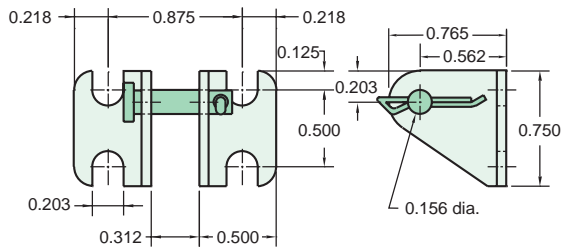

## RC-0881

Rod Clevis  
Material: steel, bright zinc plated

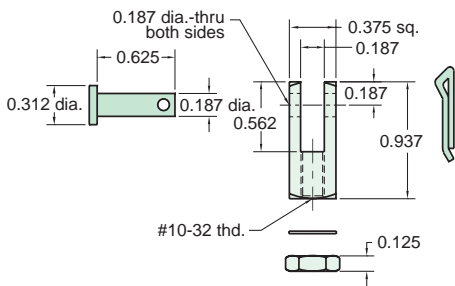

## FB-0891

Foot Bracket  
Material: steel, bright zinc plated

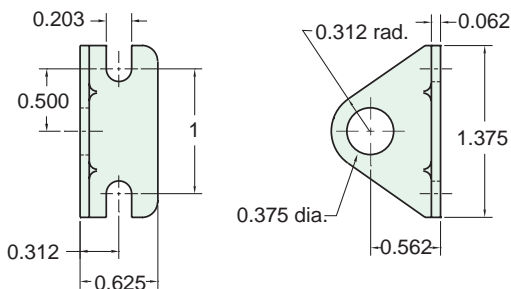

## MOUNTING NUTS

### Stud Nut

Part Number	Across Flats	Nut Thickness	Nut (Thread)
N06-24A	9/16"	7/32"	3/8-24
N06-24B	1/2"	1/8"	3/8-24
N07-20	11/16"	1/4"	7/16-20

### Rod Nut

Part Number	Across Flats	Nut Thickness	Nut (Thread)
N03-32	3/8"	1/8"	#10-32

## RE-0885

Rod End  
Material: steel, bright zinc plated body

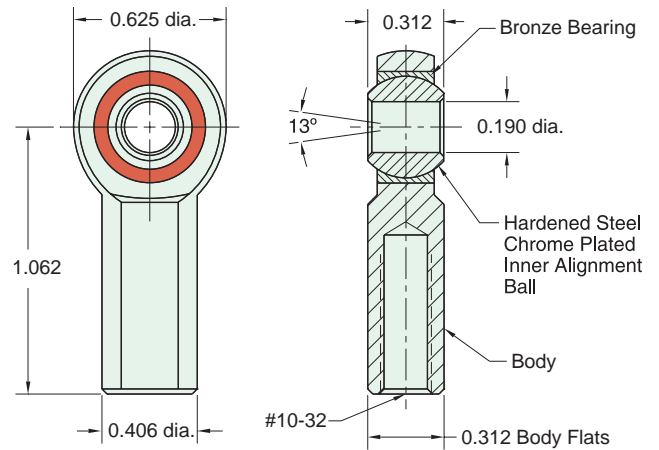

Lockwasher

Locknut

Max. Static Radial Load: 1624 lbs.  
Fits Rod Thread Size: #10-32

## FB-0892

Foot Bracket  
Material: steel, bright zinc plated

